

Gamma Scanning of Spent Fuel Element from Nuclear Power Plant

ZHU Xin-xin, WANG Xin, WANG Hua-cai, LIANG Zheng-qiang

China Institute of Atomic Energy, P. O. Box 275-57, Beijing 102413, China

Abstract

As one of non-destructive testing method in hot cells, gamma scanning is used to obtain data relevant to fuel behavior. 4 intact elements and 4 failed elements were measured with burnup range of 9600-45000MWd/tU. Axial burnup distribution and the leakage of Cs were obtained. According to the axial distribution of ^{137}Cs , total loss of Cs into the coolant is 20.9% and 27.2% respectively, for two serious damaged elements. The fuel pellet stack length growth rate was less than 0.6%.

1. Introduction

In the post-irradiation examination of spent fuel element, gamma scanning measurement, as one of the nondestructive testing method, is used to provide data relevant to fuel behavior[1], for measuring fuel pellet stack lengths, locating fuel pellet interfaces, assessing gaps between fuel pellets, studying axial distribution of burnup, and the migration of volatile fission products, which provide the basis for the irradiation performance evaluation of fuel element. 4 intact elements and 4 failed elements were measured with burnup range of 9600-45000MWd/tU. The relevant information is shown in Tab. 1. W1-W4 are complete elements and P1-P4 are failed elements. W1 and P2 are adjacent elements from the same fuel assembly. W3 and P4 are adjacent elements. The adjacent elements have similar power operation history and burnup. The remaining elements are from different assembly.

Tab. 1 Information of spent fuel elements

order	W1	W2	W3	W4	P1	P2	P3	P4
burnup (MWd/tU)	14048	23469	40433	45321	9612	13956	15624	41231
^{235}U enrichment (%)	1.8	2.4	4.45	3.7	3.1	1.8	4.2	4.45

2. Measurement

Gamma spectrometric measurement of 8 spent fuel elements from NPP has been carried out in China Advanced Research Reactor(CARR). Measurement of $^{134,137}\text{Cs}$ was performed by HPGe GC4018 detector. Scheme of measurement is shown in Fig. 1. Positioning of fuel rod in front of collimator was performed by bench. Spectroscopic software Genie2000 was used for acquirement and analysis of spectra. Photon energy interval from 0 to 1800 keV was recorded. Dead time of measurement was below 1%.

Each position (radial) of fuel element was measured via 1.6 m thick steel rectangular collimator built in the concrete wall with a 0.5mm slit. Time of measurement was set up according to the aim of the measurement from 30 s up to 60 s.

There were measured about 300 spectrums in various positions. The atom ratio $^{134}\text{Cs}/^{137}\text{Cs}$ was found to be proportional to the burnup. Atom ratios were evaluated by intrinsic efficiency calibration. In order to facilitate the comparison between the elements, the ^{137}Cs count rate and atom ratio $^{134}\text{Cs}/^{137}\text{Cs}$ are converted to the counting level at the shut-down time according to the cooling time of the fuel element.

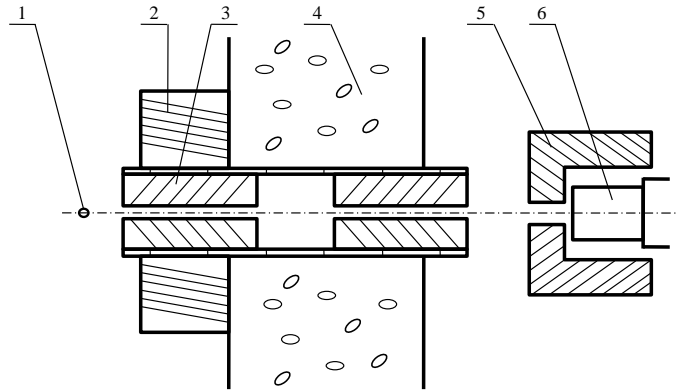

1--element, 2--lead shield, 3-- collimator, 4-- concrete wall, 5--detector shield, 6--HPGe detector
 Fig. 1 Schematic diagram of gamma scanning device

3. Results

The axial distribution curves of ^{137}Cs for four complete elements are shown Fig. 2, in which 0 is the starting point of the fuel stack at the lower end of the fuel element.

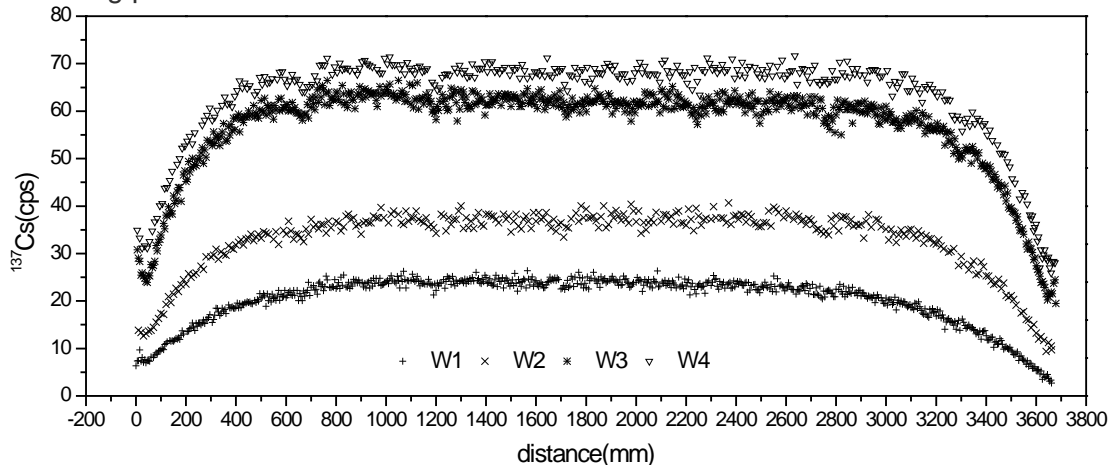

Fig. 2 ^{137}Cs axial distribution curve of 4 complete fuel elements

The axial distribution curves of ^{137}Cs for the four failed elements are shown in Fig. 3. There is a certain degree of Cs migration loss compared with the complete element. Compared with the visual inspection, it is found that the ^{137}Cs count rate is reduced in the broken position, as shown in Fig. 4 of failed element P4. The width of the ^{137}Cs reduced area is about 10mm as shown in Fig. 5, so it is suggested that the scanning interval of γ measurement should be less than 2mm for the detection of the failed element.

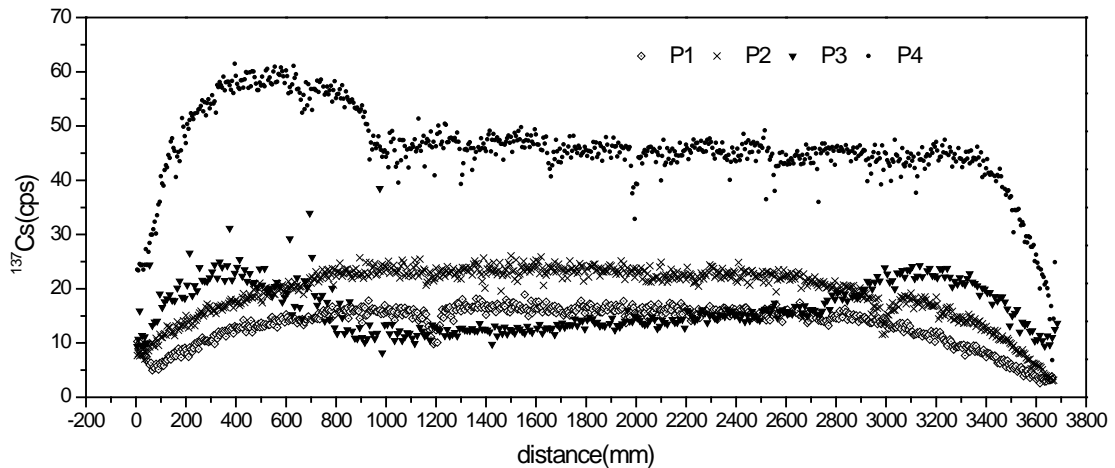

Fig. 3 ^{137}Cs axial distribution curve of 4 failed fuel elements

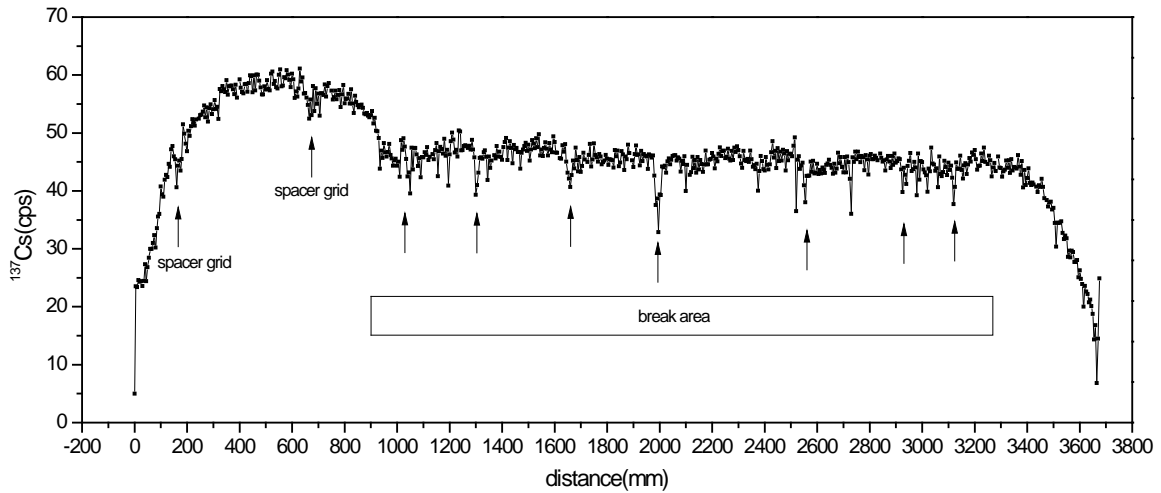

Fig. 4 ^{137}Cs axial distribution curve of P4

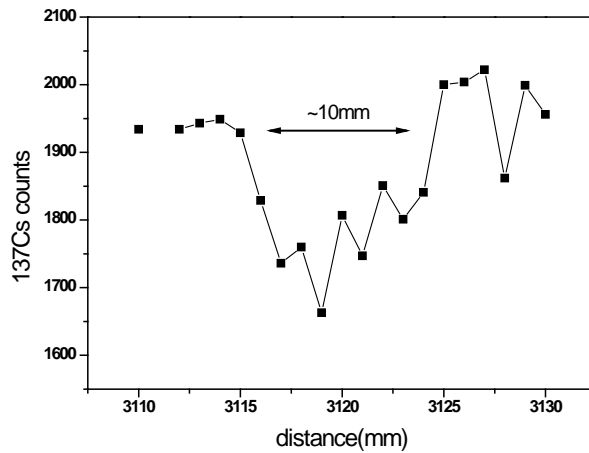

Fig. 5 ^{137}Cs distribution curve at the break position (3120mm) with 1mm interval of P4

The fuel pellet stack length is shown in Tab. 2. Compared with the nominal value 3657.6mm of the initial charge of the fuel stack, the fuel pellet stack length growth rate is between 0.1-0.6%.

Tab. 2 Fuel pellet stack length

order	W1	W2	W3	W4	P1	P2	P3	P4
pellet stack length (mm)	3661	3661	3678	3680	3665	3670	--	3675
growth rate (%)	0.09	0.09	0.56	0.61	0.20	0.34	--	0.48

As shown in Fig. 3, there is a Cs migration loss at 1200 mm of P1, and 3000 mm of P2. There is no obvious Cs migration at other positions, which is corresponding to the visual inspection. The Cs is lost in a large amount in the range of 400-3200mm of P3. Visual inspection shows that there is a large break at 980mm position, which is the main channel of Cs loss to the coolant, and it is gradient distributed to both sides of the Cs. In the range of 0-800mm, there are some partial high points, and scanning interval of 2mm was measured. There are well-regulated peaks as shown in Fig. 6. The interval between the two peaks is exactly one fuel height, which means that Cs migrate to the pellet gaps. There were still ^{137}Cs counts at 3685 mm, and showed an increasing trend. Compared with the length of the other 7 elements pellet stack length, Cs had migrated to the spring chamber.

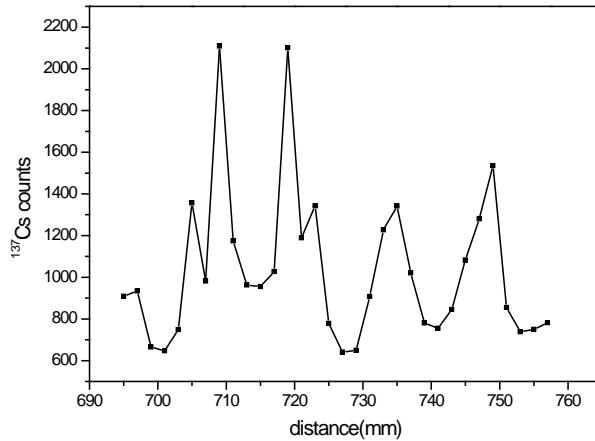

Fig. 6 Measurement of P3 with 2mm interval

There is clear Cs migration in the range of 800-3400mm of P4. In the range of 900-3400mm, it can be seen from the adjacent complete element W3 that the fuel burnup in this range is roughly equal, and in the case of multiple breaks, the Cs are uniformly migrated to coolant to form a flat distribution. Compared with the adjacent complete element W3, no Cs migration occurred at the upper and lower ends of P4.

The average counting rate of ¹³⁷Cs is obtained by dividing the fuel pellet stack length with integral of the distribution curve. The average ¹³⁷Cs count rate and fuel burnup of the 8 fuel elements are shown in Fig. 7. There is a good linear relationship between the four complete elements. The four failed elements are linearly deviated by the migration of Cs. According to the linear fitting of the complete elements, the Cs loss of P1 to P4 is reduced by 4.5%, 3.6%, 27.5% , 20.9% respectively.

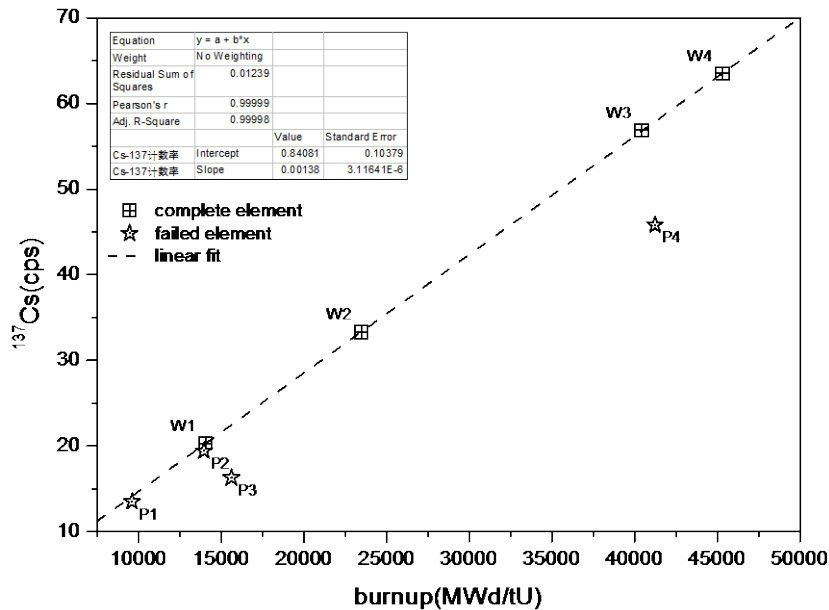

Fig. 7 Relationship between average ¹³⁷Cs count rate and fuel burnup

For the adjacent elements W3 and P4, the ¹³⁴Cs counts with a certain statistical error are obtained at the same time in the axial ¹³⁷Cs distribution measurement due to the higher fuel burnup. Atom ratios ¹³⁴Cs/¹³⁷Cs were evaluated by intrinsic efficiency calibration^[2]. The axial distribution of the atomic ratio ¹³⁴Cs/¹³⁷Cs of W3 is consistent with the axial distribution of ¹³⁷Cs, as shown in Fig. 8. The atom ratio ¹³⁴Cs/¹³⁷Cs was found to be proportional to the burnup.

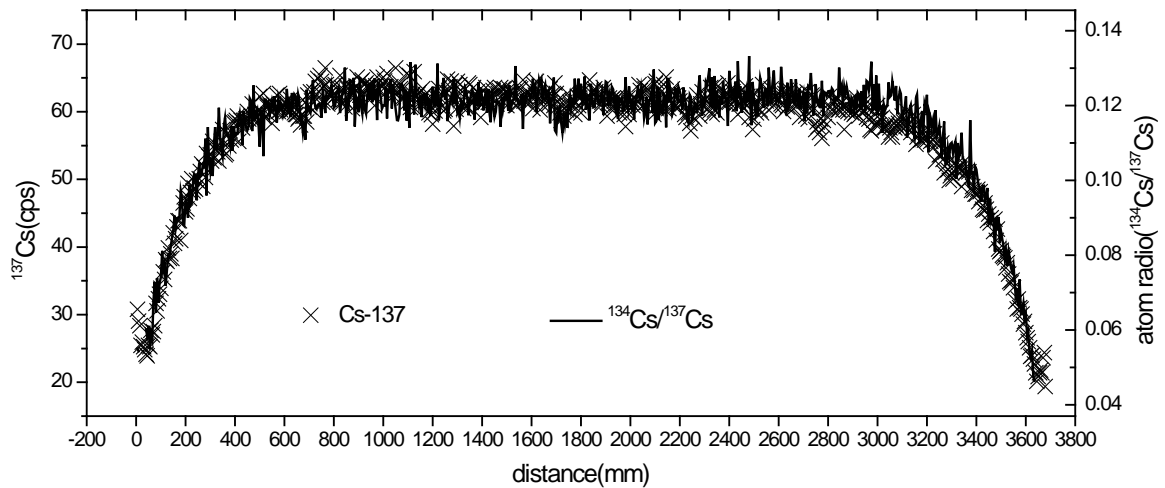

Fig. 8 Axial ^{137}Cs and $^{134}\text{Cs}/^{137}\text{Cs}$ atomic ratio distribution of intact element W3

The burnup of adjacent elements W3 and P4 is 40433MWd/tU and 41231MWd/tU, and the axial distribution of atomic ratio $^{134}\text{Cs}/^{137}\text{Cs}$ is shown in fig. 9. By the comparison of the eight order polynomial fitting curves, it is found that the atomic ratio $^{134}\text{Cs}/^{137}\text{Cs}$ of the failed element P4 are slightly higher than those of the complete element W3 in the range of 0-1000mm, which is corresponding to the slightly higher fuel burnup of the component P4. In the area of ^{137}Cs loss (i.e. 1000-3000mm), and atom ratio $^{134}\text{Cs}/^{137}\text{Cs}$ of P4 is a little smaller than the complete element W3, and the average value is 0.119, 0.122 with the difference about 2.5%. This should be associated with the formation of ^{134}Cs and ^{137}Cs . ^{137}Cs is a direct fission product.

^{134}Cs is mainly produced by path $^{133}\text{I} \xrightarrow[T_{1/2, 20.8h}]{\beta^-} ^{133}\text{Xe} \xrightarrow[T_{1/2, 5.2d}]{\beta^-} ^{133}\text{Cs} \xrightarrow{\text{neutron capture}} ^{134}\text{Cs}$, and the diffusion rate of I and Xe is slightly larger than that of Cs, which makes the ratio $^{134}\text{Cs}/^{137}\text{Cs}$ of broken elements decrease. The axial distribution of atomic ratio $^{134}\text{Cs}/^{137}\text{Cs}$ is basically the same for W3 and P4, which means that the loss proportion of ^{134}Cs and ^{137}Cs is approximately equal. So the axial relative burnup distribution can be obtained by measuring the atomic ratio $^{134}\text{Cs}/^{137}\text{Cs}$ for the failed elements with severe Cs loss.

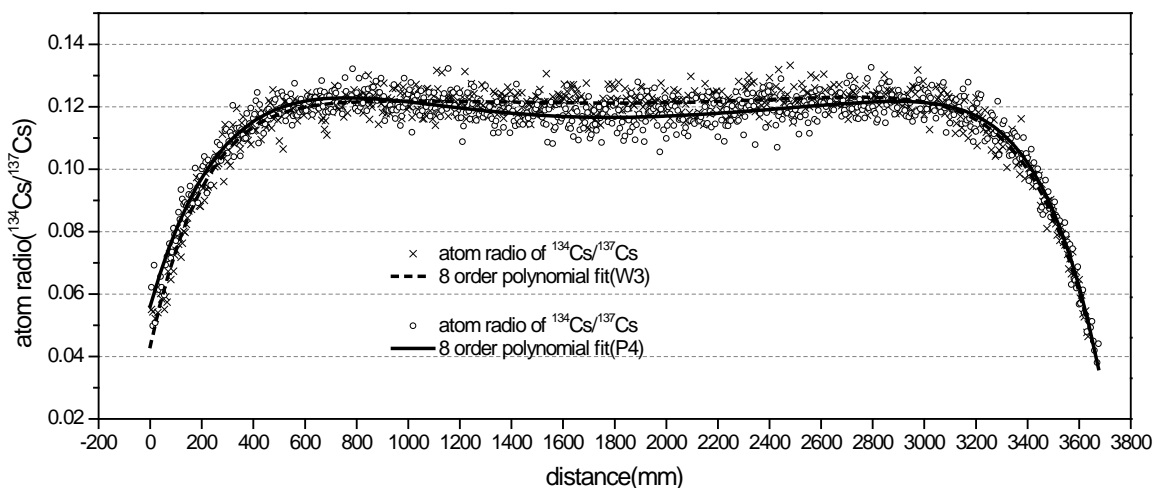

Fig. 9 Axial $^{134}\text{Cs}/^{137}\text{Cs}$ atomic ratio distribution of sibling elements W3 and P4

4. Summary

4 complete elements and 4 failed elements from NPP were measured with burnup range of 9600-45000MWd/tU. Axial burnup distribution and the leakage of Cs were obtained. The fuel pellet stack length growth rate was less than 0.6%. It is recommended that the measurement interval of the failed element is not greater than 2mm. The loss proportion of ^{134}Cs and ^{137}Cs is approximately equal during Cs leakage, and the atomic ratio $^{134}\text{Cs}/^{137}\text{Cs}$

can be used to characterize the axial relative fuel burnup distribution. According to the axial distribution of ^{137}Cs , total loss of Cs into the coolant is 20.9% and 27.2% respectively, for two serious damaged elements.

References

- [1] INTERNATIONAL ATOMIC ENERGY AGENCY, Guidebook on Non-destructive Examination of Water Reactor Fuel, Technical reports series No.322, IAEA, Vienna, 1991
- [2] Heemoon Kim, Hong-ki Lee, et al. Burnup Estimation of Nuclear Fuels with a Gamma Scanning Test, IAEA-TECDOC-CD-1635, IAEA, Vienna , 2009